

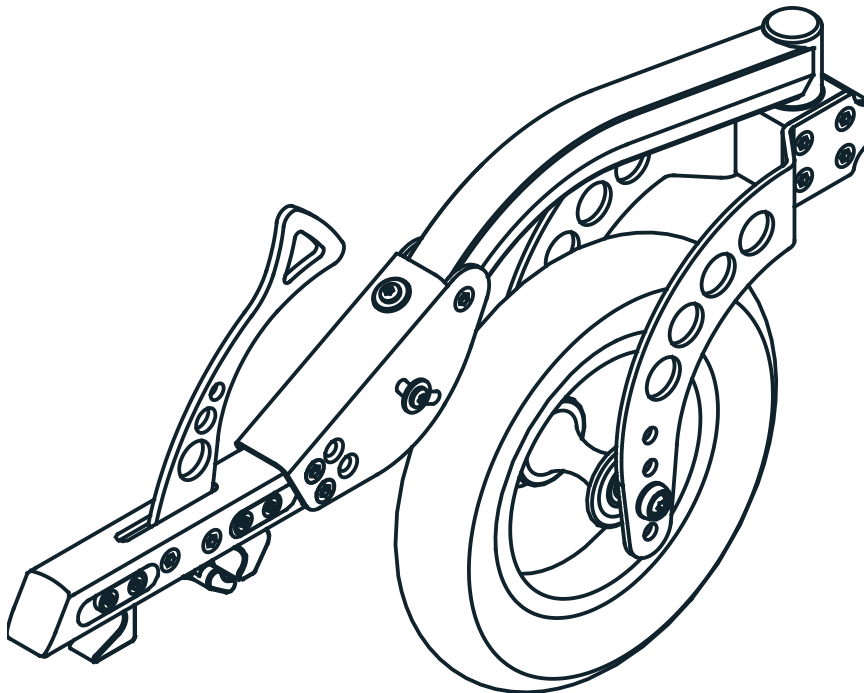

Adventus User manual





The undersigned, representing the following manufacturer

Decon Wheel AB
Org. No. 556618-9006
SRN SE-MF-000046289
Södra Ekeryd 119, 314 91 Hyltebruk
Sweden,

hereby declares that the product **Adventus**

with the basic UDI-DI 735001014ADVA8

and the following references

ADV4500	ADV4550
ADV4510	ADV4560
ADV4520	ADV4570
ADV4530	ADV4580
ADV4540	

is in conformity with the Medical Device Regulation (EU) 2017/745 as a class I medical device based on Annex VIII.

Intended purpose: Adventus is an accessory designed to be connected to a manual wheelchair to facilitate mobility on uneven surfaces. The device is intended for outdoor use.

This EU declaration of conformity is issued under the sole responsibility of the manufacturer.

Hyltebruk, 2025-10-24

Mattias Lundin
CEO



Innehåll

Security	4
General instructions	4
Manuals for the visually impaired	4
Purpose and normal use	4
Improper use.....	4
Symbols.....	4
Warnings.....	5
Waste management.....	6
Labelling	7
Reuse.....	7
Warranty	8
Information on product safety and recalls	8
Product description	9
General	9
Technical data.....	9
Delivery scope	9
Overview.....	10
Features.....	10
Mechanical settings	11
To mount Adventus for the first time	11
To use Adventus	15
Care	17
Cleaning	17
Repairs	17

Security

General instructions

The user manual is written for users of Adventus and people who in some way are assisting the user to ensure an optimal use of Adventus.

Read the user manual and make yourself well known with Adventus before using it.

Manuals for the visually impaired

If you have difficulty reading this user manual, please contact your local retailer. Your local retailer can provide you with a digital copy of this manual. This makes it possible to enlarge the print or have your reading software read it aloud to you.

Purpose and normal use

Adventus is an accessory designed to be connected to a manual wheelchair to facilitate mobility on uneven surfaces. When Adventus is connected to the wheelchair, the casters are lifted. This means that only the rear wheels of the wheelchair are used.

Adventus can be mounted both on rigid frame and folding frame wheelchairs. When mounting Adventus on a wheelchair without rigid footrest an adapter is required.

For information on which wheelchair models Adventus can be mounted, see Decon's website, www.decon.se/en

Improper use

Any use that does not follow the description in this user manual. This also includes the technical specification.

Symbols



WARNING!

Risk of serious injury or death.

An operation that, if not correctly performed, may lead to injury to the operator or others.



CAUTION!

Risk of material damage.

An operation that, if not correctly performed, may lead to material damage.



INFO!

Particularly important or explanatory information.

Warnings

Before you use Adventus for the first time

**WARNING!**

The user should have read and understood the manual and have an understanding of how Adventus works.

**WARNING!**

Before using Adventus, assess your skills and determine if you need an assistant. To decide whether you need an assistant, you should also request an expert opinion for reference.

If your assessment is based solely on your own perception, you or the people around you could be injured.

**WARNING!**

Practice running on even ground in a safe environment together with an assistant, until you feel confident about how Adventus works.

If you are driving on public roads, even though you are not sure how to use Adventus, you or other people around you can be injured.

Driving

**WARNING!**

Keep in mind that Adventus allows the wheelchair to be longer at the front, so that you do not injure yourself or others in your environment.

**WARNING!**

Keep in mind that Adventus is not for play or sports, but is an aid to make it easier to get forward on such as snow, sand or grass, etc.

**INFO!**

Check tyre pressure before using Adventus.

Public transport

**WARNING!**

Do not have Adventus mounted on the footrest when travelling by public transport. Hang Adventus on the transport holder.

Storage and transport



WARNING!

Use straps to ensure that Adventus can be transported safely.



CAUTION!

Never transport Adventus connected to a wheelchair.



CAUTION!

Place Adventus so that no parts are damaged during transport.

Cleaning



CAUTION!

Adventus is suitably cleaned with compressed air or a dry plastic brush and a damp cloth. If it is really dirty, use a mild detergent solution. Wipe with a soft cloth and air dry.



CAUTION!

Do not use corrosive or abrasive cleaning agents.



INFO!

Adventus is appropriately disinfected by using a cloth with alcohol.

Other



WARNING!

It is extremely important that all the screws are properly tightened after setting up.

Waste management

Once Adventus has served and is to be scrapped, contact the local authorities to obtain information about recycling and follow their instructions.

Alternatively, you can contact your reseller for recycling your used Adventus.

Labelling

Type plate

The type plate and a label showing the year of manufacture and month are placed on the underside of the frame.



Reuse

When Adventus is to be transferred to a new user, all technical documents must also be transferred. The product must be cleaned by a professional, disinfected and serviced.

Warranty

The warranty period for Adventus is 2 (two) years from the date of purchase.

If there is a material or workmanship defect on your copy of Adventus during this warranty period, the defective parts will be replaced or repaired free of charge. Consumable parts such as tyres and hoses are excluded from this warranty.

This warranty does not cover faults caused either by deliberate misuse on the part of the user or by negligent use, e.g. faults caused by use other than that specified in these user instructions. Nor does this warranty cover faults arising as a result of modifications to the device or continuous use under conditions other than those specified.

Scratches, dulling and dirt on the surface of the product resulting from normal use are not covered by the warranty.

If warranty repairs are required, contact the retailer you purchased the device from.

The expected service life of the complete product (not wearing parts) is five years from the date of sale.

Information on product safety and recalls

Contact the retailer where the device was purchased or the manufacturer of Liberty for information about product safety and any recalls.

In the event of serious incident, contact the manufacturer or retailer for further reporting to appropriate authority

Product description

General

Adventus is an accessory designed to be connected to a manual wheelchair to facilitate mobility on uneven surfaces. This is achieved by connecting Adventus to the wheelchair's footrest with the wheel in its front position, thereafter the wheel is to be rotated. When the wheel on Adventus is rotated, the wheelchair's castors lift from the ground. The angle, α , in which Adventus is installed determines how much the castors of the wheelchair will lift from the ground.

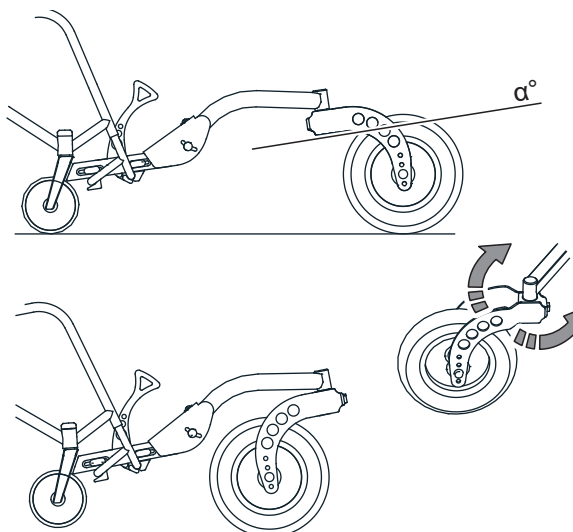

Technical data

Length	approx. 450 mm in front of the front tube of the footrest
Height	approx. 350 mm from surface
Wheel size	10" x 2"
Air pressure in tyre	2,0 bar / 200 kPa
Weight	2,45 kg

Delivery scope

The delivery of Adventus includes the following:

- A Adventus
- B User manual
- Transport holder (optional)

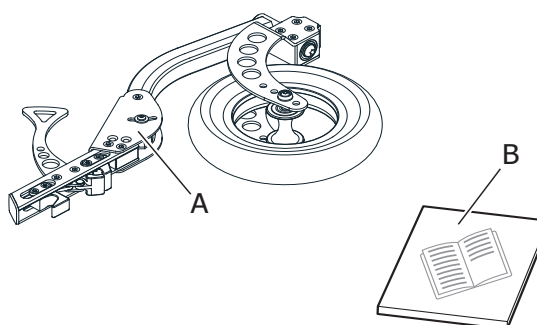

Transport holder



Transport holder is ordered separately.

To transport Adventus on a wheelchair, a transport holder is required.

Overview

Adventus consists mainly of the following parts.

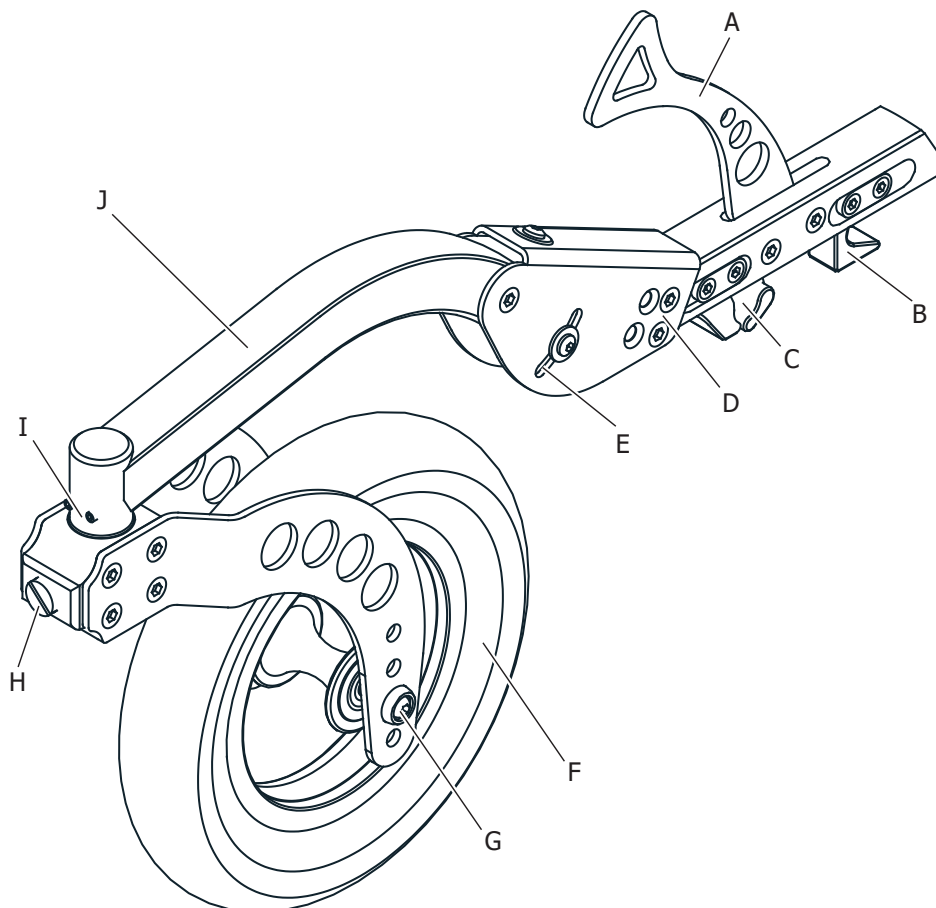

A	Locking lever	F	Wheel
B	Rear attachment	G	Wheel fork with height adjustment
C	Front attachment and lock	H	Adjustment screw for swing inertia
D	Angle adjustment of u-profile	I	Steering link with adjustment screws
E	Link for angle adjustment	J	Framework

Features

The attachments (B) (C) are adjustable to suit different footrests. With the angle adjustment (D), link (E) and the wheel attachment in the fork (G) the lift height can be adjusted. The wheel alignment and inertia are adjusted with the screws in the steering link (I) and the screw (H).



WARNING!

In some cases there is a need for a reinforced footrest when used in combination with Adventus. Contact the wheelchair manufacturer for more information.

Mechanical settings

To mount Adventus for the first time

Before mounting Adventus check,

- which footrest the wheelchair manufacturer recommends.
- that the distance between the front and rear tube of the footrest is as shown in the table below.

Adventus is available in standard and in long design depending on the distance between the tubes of the footrest.

Adventus standard

Tube diameter [mm]	15	16	17	18	19	20	25
Distance [mm]	71,0–94,5	74,5–98,3	77,9–101,7	81,4–105,2	85,1–108,9	88,2–112,0	80-105

Adventus long

Tube diameter [mm]	15	16	17	18	19	20	25
Distance [mm]	90–135	93–138	97–142	100–145	104–149	107–152	100-145

To customize Adventus

1. Measure the height from ground up to underneath the front tube of the wheelchair's footrest. Now set the angle position (D) and wheelposition (G) according to the table below.

i INFO!

Using the settings in the table below normally results in lifting the front castors of the wheelchair 30-40mm from the ground.

i INFO!

The settings in the table below can vary between different wheelchair models and manufacturers. The table shows a wheelchair where the footrest sits in an angle of 6-7degrees in relation to the ground.

Height footrest [mm]	0-30	30-50	50-70	70-90	90-100	100-
Angle position (D) [D0, D1]	D0	D0	D0	D0	D1	D1
Wheel position (G) [G1, G2, G3, G4]	G1	G2	G3	G4	G3	G4

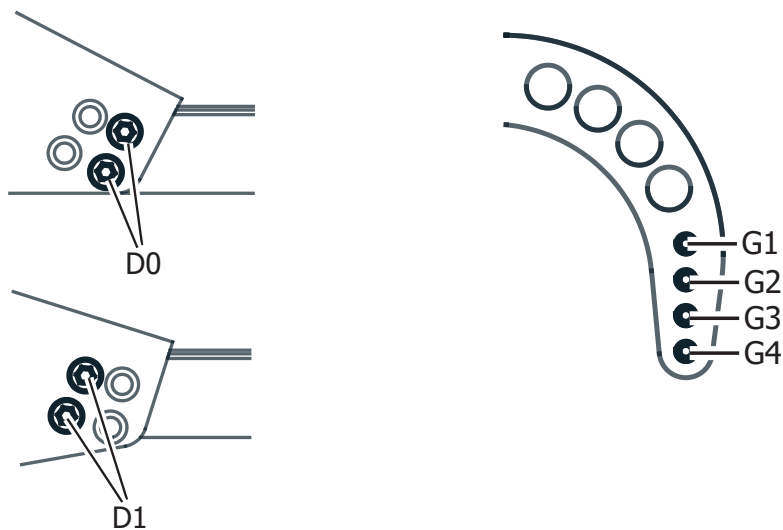

2. Fold up the locking lever (A) to open the front attachment (C).
3. Loosen the screw (K) on the underside of the frame.
Loosen the locking screws (L) and move the front attachment (C) as far back as possible.
4. Loosen the locking screws (M) and move the rear attachment (B) as far back as possible.
5. Loosen screws (N) and the adjustment screw (O) so that the screws (N) can move freely inside the track for angle adjustment (E).

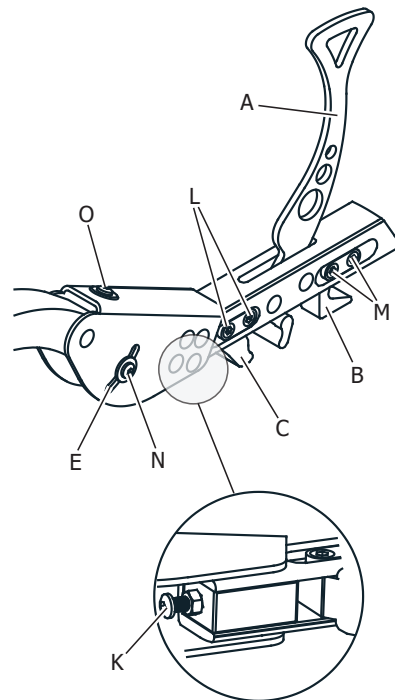

6. Put the wheel in its front position, put Adventus in place on the footrest by inserting the attachment (B) so that it locks into the rear tube of the footrest.
Lower the wheel to the ground level and lock the front tube of the footrest by folding down the locking lever (A).

Tighten the screw (K) until the front attachment (C) locks against the footrest.

Tighten the locking screws (L).

7. Press the rear attachment (B) back with your hand so that it locks against the rear tube of the footrest.

Tighten the locking screws (M).

8. Adjust the adjustment screw (O) until the wheelchair's front castors are just lifted from the ground. Tighten the screws (N) on both sides.

9. Turn the wheel to its rear position and check that the front castors lift from the ground. Recommended height is 30-40mm.

If the front castors are not lifted enough from the ground then, if possible, move the wheel to a higher position in the fork. If the wheel position is changed the adjustment screw (O) and screws (N) must be loosened again to remake the adjustment from item 8.

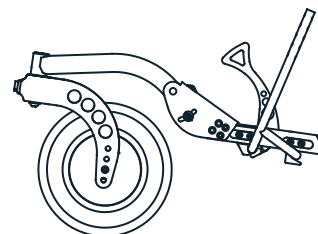
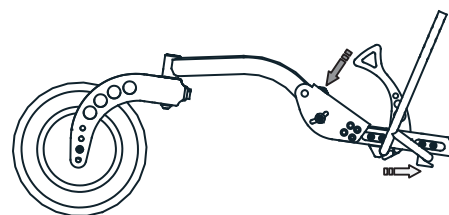
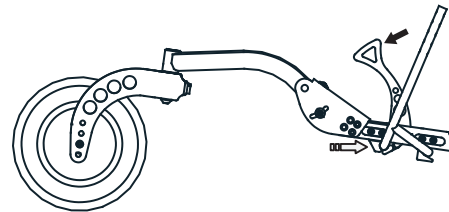

10. Adjust the swing inertia by tightening or loosening the screw (H) in the steering link.

Make sure the wheel is aligned with the frame. If this needs to be adjusted start by loosening the screw (P). Then loosen or tighten the adjustment screws (I) to align the wheel. Finish by tightening the screw (P).

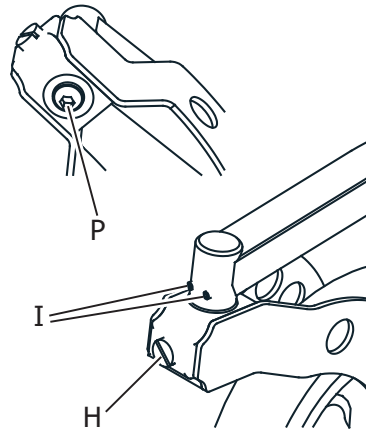

WARNING!

The screw (P) must be tightened with a torque of 25-30Nm

To use Adventus



WARNING!

The user should have read and understood the manual and have an understanding of how Adventus works.

Connecting Adventus to your wheelchair

1. Set the wheel in its front position.
2. Fold up the locking lever to open the front attachment.
3. Fit Adventus in the middle of the footrest.
4. Fold down the locking lever to its locked position.
5. Turn the wheel to its rear position to lift the castors from the ground

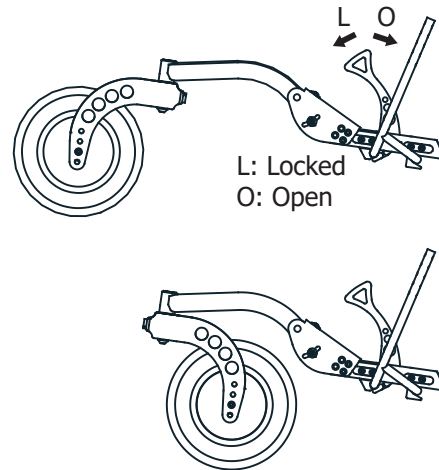

Transport of Adventus



WARNING!

Use straps to ensure that Adventus can be transported safely.



CAUTION!

Place Adventus so that no parts are damaged during transport.



CAUTION !

Never transport Adventus connected to a wheelchair.

Transport of Adventus on wheelchair

The transport holder is extra equipment.

Hang Adventus on the transport holder.

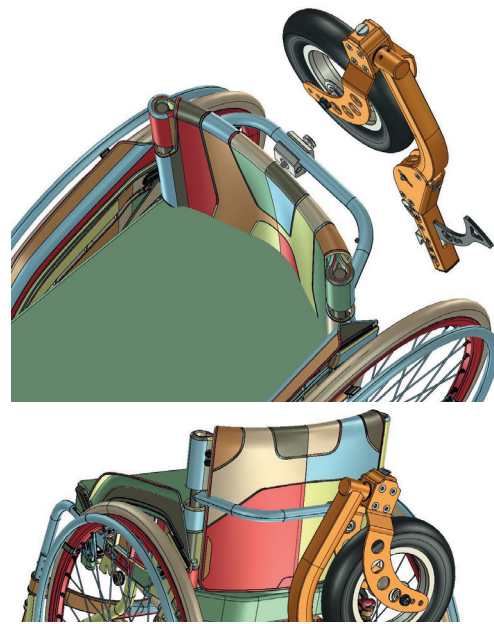

Care

Cleaning

If Adventus becomes dirty due to normal use, clean Adventus with a damp, hard wrung, towel. If Adventus is heavily soiled use a towel and a neutral detergent. Make sure that no cleaning agent is left on Adventus after cleaning.

CAUTION!

Do not clean with solvents such as benzene or thinner. This may damage lacquer and plastic parts on Adventus

INFO!

Adventus is appropriately disinfected by using a cloth with alcohol.

Repairs

The user must not self-repair or service Adventus.

The user must not self-remove and send parts of Adventus to the dealer for repair.

If a repair is required, contact your retailer, even if the fault is of a minor nature.

If parts are damaged or missing, contact the retailer immediately. Submit Adventus to the retailer for replacement or repair of parts.

For normal maintenance, repair or service, always contact the retailer. If Adventus is not repaired or all parts are not used in assembly, the user, the persons in its environment or the property may be damaged.

To perform repairs and servicing, the retailer uses the spare parts catalogue and other documentation. This documentation is not available to users and the general public.

Punctures

INFO!

The tyre on Adventus has the same structure as a bicycle tire. Therefore, as a rule, a bicycle workshop can repair puncture and change tire on Adventus. If you do not have access to a bicycle workshop, please contact your dealer.

Decon Wheel AB
Södra Ekeryd 119, 314 91 Hyltebruk
Tel: +46 (0)345 40880
Fax: +46 (0)345 40895
E-mail: info@decon.se

